

Lampada custom in alluminio anodizzato bianco 3metri a sospensione, cover opale, ganci inox tenuta e tappi, LED 75W 150lm/W PROFESSIONALE, alimentatore stabilizzato DALI2

Codice: **TECHNOLINE 3000 CUSTOM**

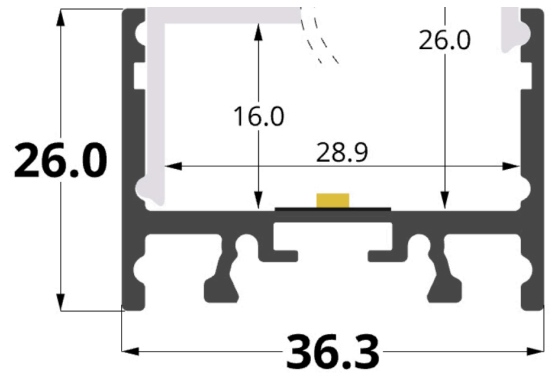

L'INSTALLAZIONE DI QUESTO APPARECCHIO DEVE ESSERE EFFETTUATA DA PERSONALE QUALIFICATO
THE LIGHTING FITTING SHOULD BE INSTALLED BY A QUALIFIED ELECTRICIAN

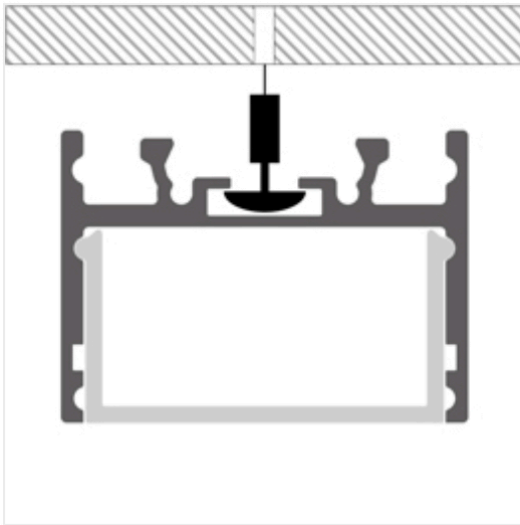
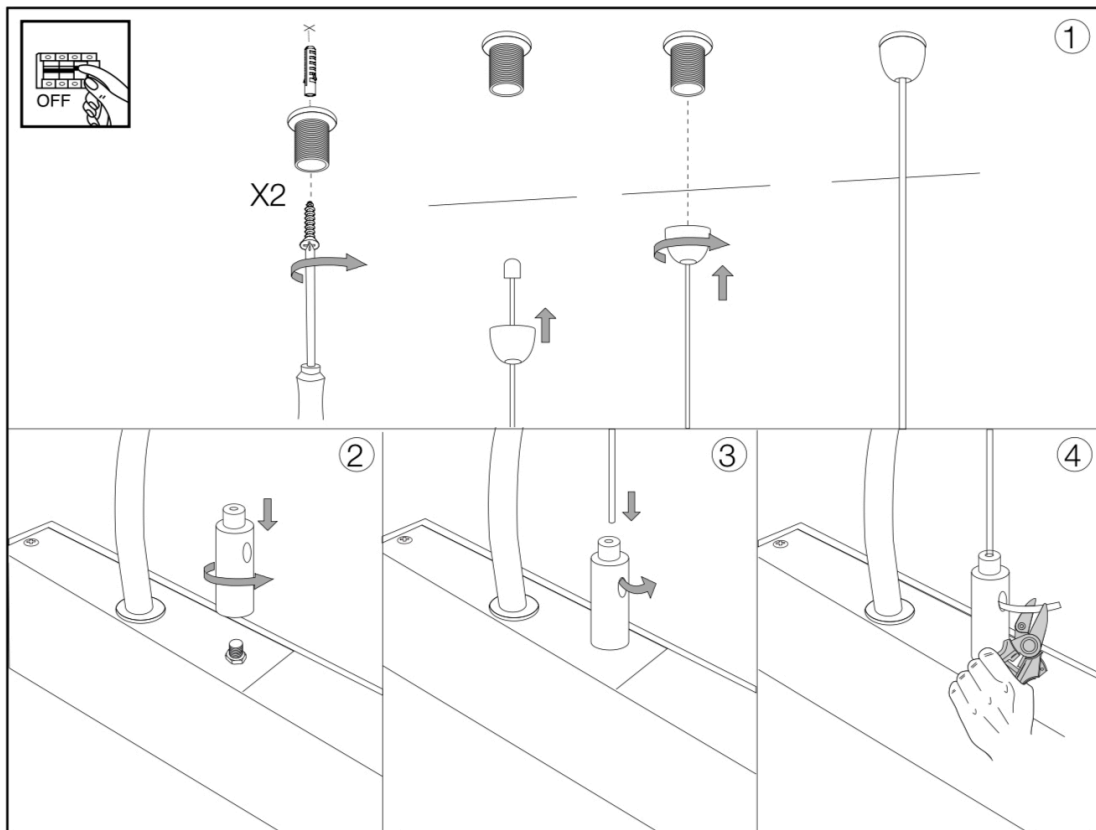

Specifiche tecniche:

Numero Led: 160/mt

Potenza nominale: 75W

Tensione alimentazione: DC24V

Dimmerabile : DRIVER DALI STABILIZZATO (driver esterno alla lampada)

Tipologia Led: SMD2835 H.E.

Efficienza: 150Lm/W

Angolo Luce : 120°

Indice di resa cromatica: 90+

Protezione: IP40

Certificati: TUV , RoHS , CE

